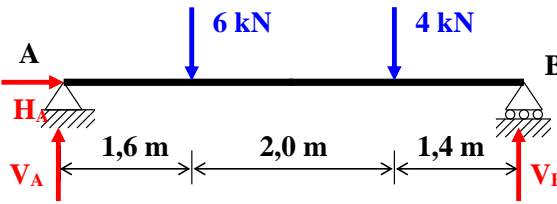
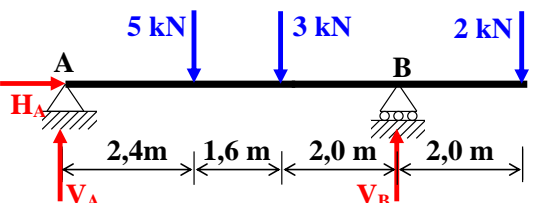
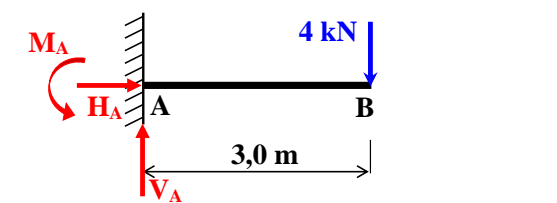
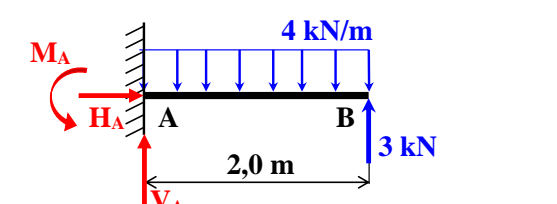
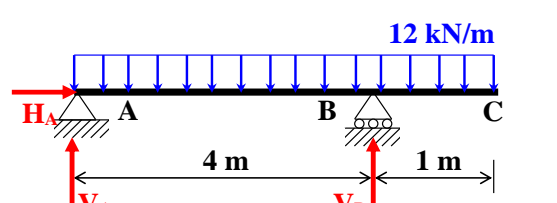
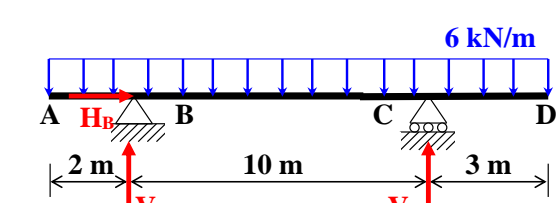
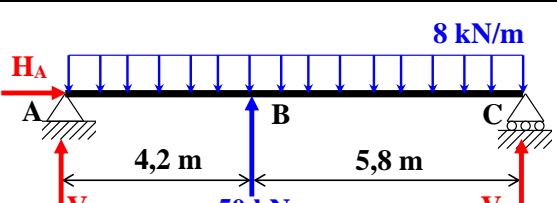

Lista de Exercícios – Reações de Apoio em vigas isostáticas

Calcule as reações de apoio das vigas isostáticas representadas pelas figuras abaixo:

<p>a)</p> 	$\therefore H_A = 0,00 \text{ kN}$ $\therefore V_A = 5,20 \text{ kN}$ $\therefore V_B = 4,80 \text{ kN}$
<p>b)</p> 	$\therefore H_A = 0,00 \text{ kN}$ $\therefore V_A = 3,33 \text{ kN}$ $\therefore V_B = 6,67 \text{ kN}$
<p>c)</p> 	$\therefore H_A = 0,00 \text{ kN}$ $\therefore M_A = 12,0 \text{ kN.m}$ $\therefore V_A = 4,00 \text{ kN}$
<p>d)</p> 	$\therefore H_A = 0,00 \text{ kN}$ $\therefore M_A = 2,00 \text{ kN.m}$ $\therefore V_A = 5,00 \text{ kN}$
<p>e)</p> 	$\therefore H_A = 0,00 \text{ kN}$ $\therefore V_A = 22,5 \text{ kN}$ $\therefore V_B = 37,5 \text{ kN}$
<p>f)</p> 	$\therefore H_B = 0,00 \text{ kN}$ $\therefore V_B = 40,5 \text{ kN}$ $\therefore V_C = 49,5 \text{ kN}$
<p>g)</p> 	$\therefore H_A = 0,00 \text{ kN}$ $\therefore V_A = 11,0 \text{ kN}$ $\therefore V_C = 19,0 \text{ kN}$

Lista de Exercícios – Reações de Apoio em vigas isostáticas

Calcule as reações de apoio das vigas isostáticas representadas pelas figuras abaixo:

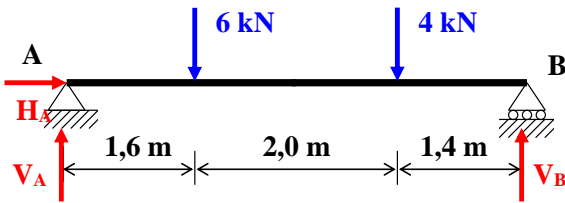

a)

Solução:

$$\sum F_x = 0 \therefore H_A = 0,00 \text{ kN}$$

$$\sum (M_z)_B = 0 \Rightarrow V_A \times 5 - 6 \times 3,4 - 4 \times 1,4 = 0 \Rightarrow V_A = \frac{6 \times 3,4 + 4 \times 1,4}{5} \therefore V_A = 5,20 \text{ kN}$$

$$\sum F_y = 0 \Rightarrow V_A + V_B - 6 - 4 = 0 \Rightarrow V_B = 6 + 4 - 5,2 \therefore V_B = 4,80 \text{ kN}$$

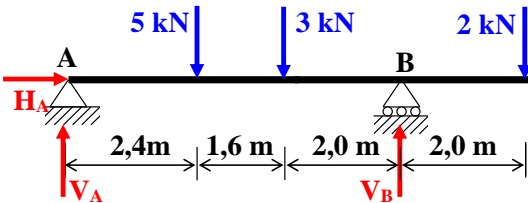

b)

Solução:

$$\sum F_x = 0 \therefore H_A = 0,00 \text{ kN}$$

$$\sum (M_z)_B = 0 \Rightarrow V_A \times 6 - 5 \times 3,6 - 3 \times 2,0 + 2 \times 2,0 = 0 \Rightarrow V_A = \frac{20}{6} \therefore V_A = 3,33 \text{ kN}$$

$$\sum F_y = 0 \Rightarrow V_A + V_B - 5 - 3 - 2 = 0 \Rightarrow V_B = 10 - 3,33 \therefore V_B = 6,67 \text{ kN}$$

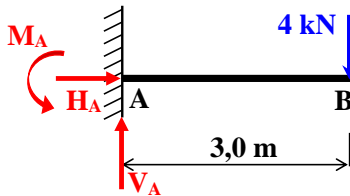

c)

Solução:

$$\sum F_x = 0 \therefore H_A = 0,00 \text{ kN}$$

$$\sum (M_z)_A = 0 \Rightarrow M_A - 4 \times 3,0 = 0 \therefore M_A = 12,0 \text{ kN.m}$$

$$\sum F_y = 0 \Rightarrow V_A - 4 = 0 \therefore V_A = 4,00 \text{ kN}$$

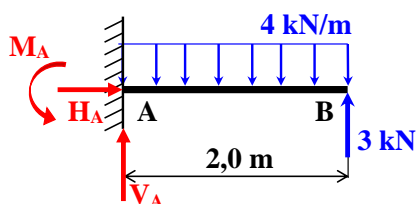

d)

Solução:

$$\sum F_x = 0 \therefore H_A = 0,00 \text{ kN}$$

$$\sum (M_z)_A = 0 \Rightarrow M_A + 3 \times 2,0 - (4 \times 2,0) \times \frac{2,0}{2} = 0 \therefore M_A = 2,00 \text{ kN.m}$$

$$\sum F_y = 0 \Rightarrow V_A + 3 - (4 \times 2,0) = 0 \therefore V_A = 5,00 \text{ kN}$$

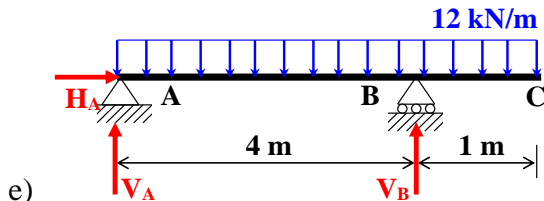

Solução:

$$\sum F_x = 0 \therefore H_A = 0,00 \text{ kN}$$

$$\sum (M_z)_B = 0 \Rightarrow V_A \times 4 - (12 \times 5,0) \times 1,5 = 0 \therefore V_A = 22,5 \text{ kN}$$

$$\sum F_y = 0 \Rightarrow V_A + V_B - (12 \times 5,0) = 0 \Rightarrow V_B = 60 - 22,5 \therefore V_B = 37,5 \text{ kN}$$

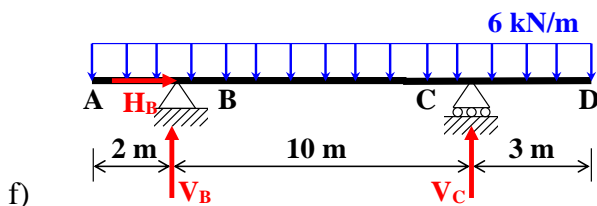

Solução:

$$\sum F_x = 0 \therefore H_B = 0,00 \text{ kN}$$

$$\sum (M_z)_C = 0 \Rightarrow V_B \times 10 - (6 \times 15) \times 4,5 = 0 \therefore V_B = 40,5 \text{ kN}$$

$$\sum F_y = 0 \Rightarrow V_B + V_C - (6 \times 15) = 0 \Rightarrow V_C = 90 - 40,5 \therefore V_C = 49,5 \text{ kN}$$

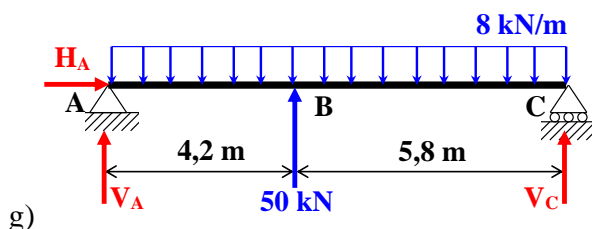

Solução:

$$\sum F_x = 0 \therefore H_A = 0,00 \text{ kN}$$

$$\sum (M_z)_B = 0 \Rightarrow V_A \times 10 - (8 \times 10) \times 5 + 50 \times 5,8 = 0 \therefore V_A = 11,0 \text{ kN}$$

$$\sum F_y = 0 \Rightarrow V_A + V_C - (8 \times 10) + 50 = 0 \therefore V_C = 19,0 \text{ kN}$$